



GS Technical Data Sheet

GS GS-M26-80S - GS Marine Battery

Performance

| | |
|--------------------------|------|
| Voltage | 12V |
| Capacity (20-hour) | 80Ah |
| Cold Cranking Amps (EN1) | 600A |

Dimensions

| | |
|--------|-------|
| Length | 260mm |
| Width | 174mm |
| Height | 225mm |

Weights & Measures

| | |
|-----------------------|--------|
| Mean Weight with Acid | 18.9kg |
|-----------------------|--------|

Container Features

| | |
|---------------------------|----------------|
| Case Type | GR24 BCI |
| Cell Layout | 1 |
| Hold Down | B1 |
| State of Charge Indicator | ✓ |
| Handles | ✓ |
| End Venting | ✓ |
| Semi-Traction Features | ✓ |
| Lid Type | SMF Double Lid |



Technology

| | |
|---------------------------|------------------|
| Flame Arrestor Technology | ✓ |
| Separator | Ca/Ca |
| Vibration | PE |
| Recommended Charge Rate | V1 (30Hz/3g/2hr) |
| | 4A |

Terminal Type

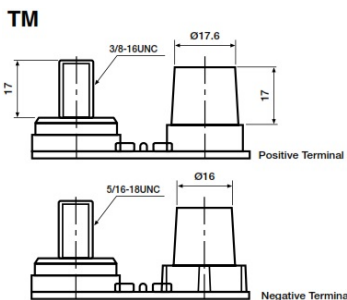

Cell Assembly Layout

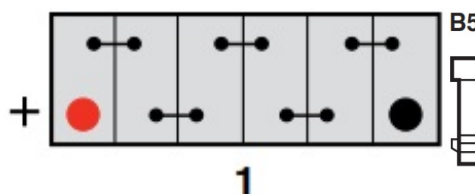

Battery Hold-down

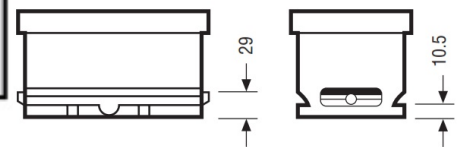

Data Sheet generated on 27/03/2023 - E&OE