



GS Technical Data Sheet

GS GS-M31-100S - GS Marine Battery

Performance

Voltage	12V
Capacity (20-hour)	100Ah
Cold Cranking Amps (EN1)	750A

Dimensions

Length	330mm
Width	173mm
Height	240mm

Weights & Measures

Mean Weight with Acid	23.5kg
-----------------------	--------



Container Features

Case Type	GR31 BCI
Cell Layout	1
Hold Down	N
State of Charge Indicator	✓
Handles	✓
End Venting	✓
Semi-Traction Features	✓
Lid Type	SMF Double Lid

Technology

Flame Arrestor Technology	✓
Separator	Ca/Ca
Vibration	PE
Recommended Charge Rate	V1 (30Hz/3g/2hr)
	5A

Terminal Type

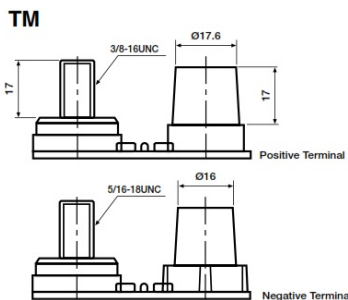

Cell Assembly Layout

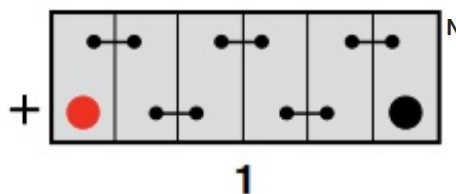

Battery Hold-down



Data Sheet generated on 27/03/2023 - E&OE